



US 20070176563A1

(19) **United States**

(12) **Patent Application Publication**
Kim et al.

(10) **Pub. No.: US 2007/0176563 A1**

(43) **Pub. Date: Aug. 2, 2007**

(54) **ORGANIC LIGHT EMITTING DISPLAY
DEVICE AND A METHOD OF
MANUFACTURING THEREOF**

Publication Classification

(51) **Int. Cl.**
G09G 3/10 (2006.01)
(52) **U.S. Cl.** **315/169.3; 313/504; 313/512;
345/76; 313/505**

(76) **Inventors: Deuk Jong Kim, Gyeonggi-do
(KR); Seung Yong Song,
Gyeonggi-do (KR)**

(57) **ABSTRACT**

Correspondence Address:
**KNOBBE MARTENS OLSON & BEAR LLP
2040 MAIN STREET, FOURTEENTH FLOOR
IRVINE, CA 92614**

Discloses is an organic light emitting display device including a first substrate divided into a pixel region and a non-pixel region. An organic light emitting element includes a first electrode, an organic thin film layer and a second electrode formed in the pixel region. A scan driver and a metal film corresponding to a region of the scan driver are formed in the non-pixel region. A second substrate is spaced apart from the pixel region and the non-pixel region of the first substrate. A frit is formed along an edge of a non-pixel region of the second substrate, wherein the frit is formed so that it can be overlapped with an active area of the scan driver formed in the non-pixel region.

(21) **Appl. No.: 11/540,083**

(22) **Filed: Sep. 29, 2006**

(30) **Foreign Application Priority Data**

Jan. 27, 2006 (KR) 10-2006-0008768

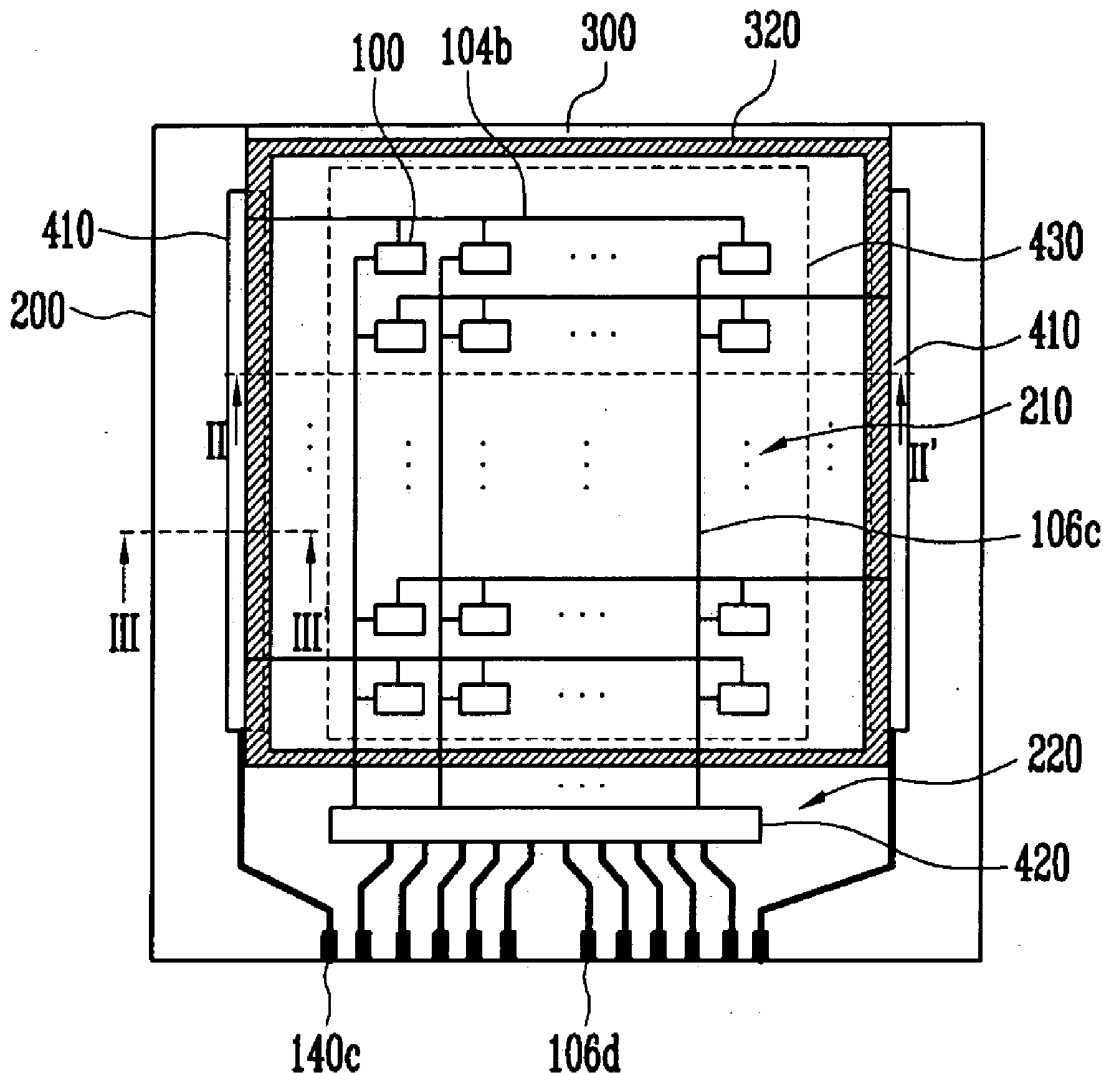

FIG. 2

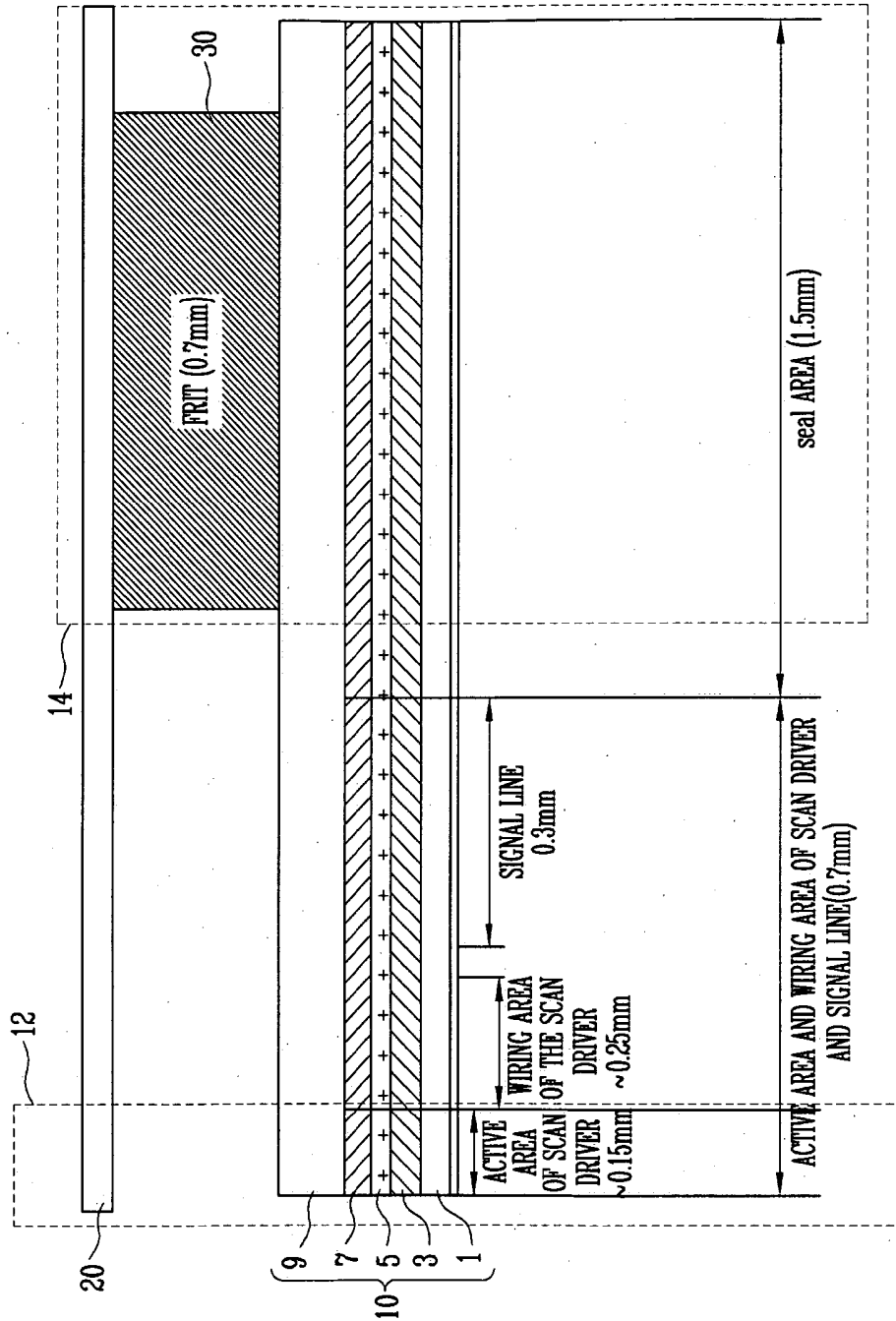

FIG. 3

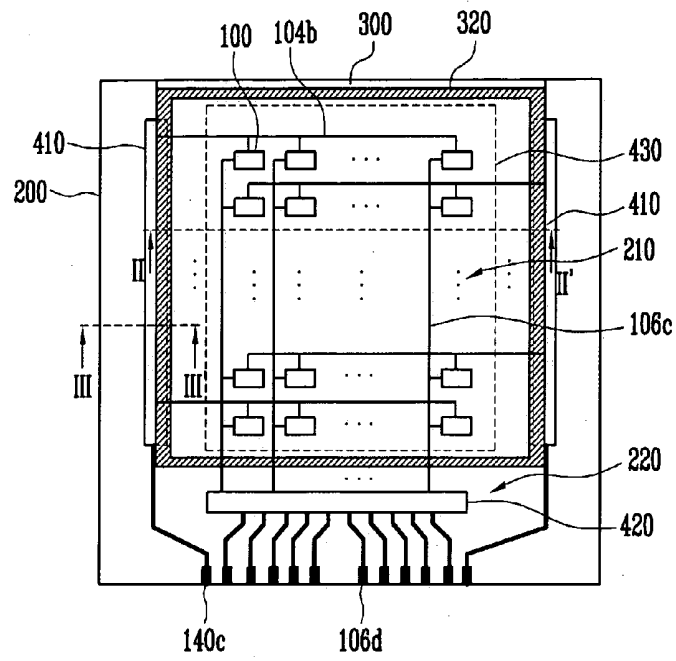

FIG. 4

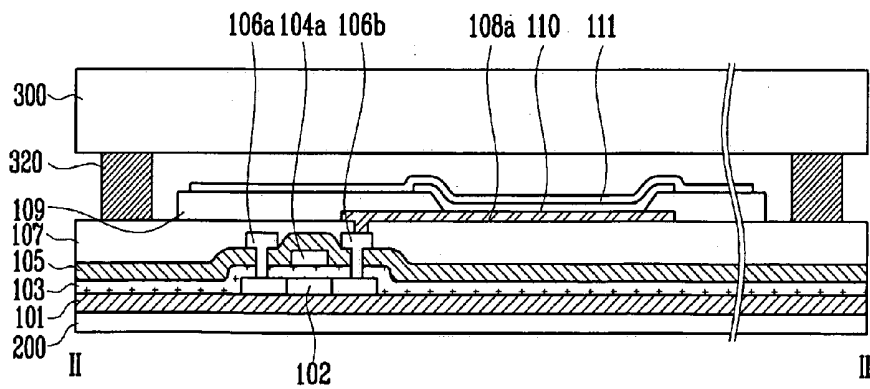

FIG. 5

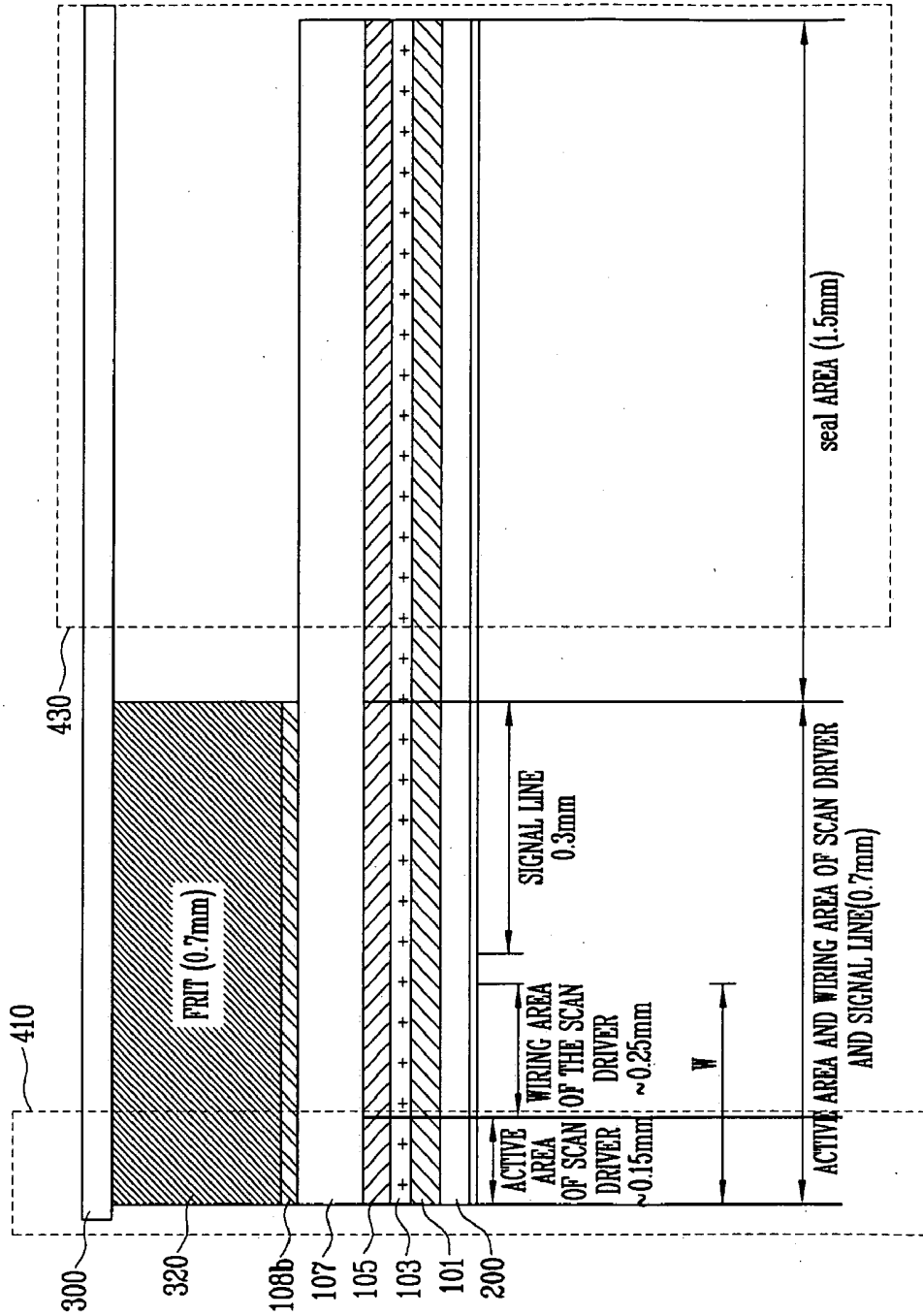

FIG. 6

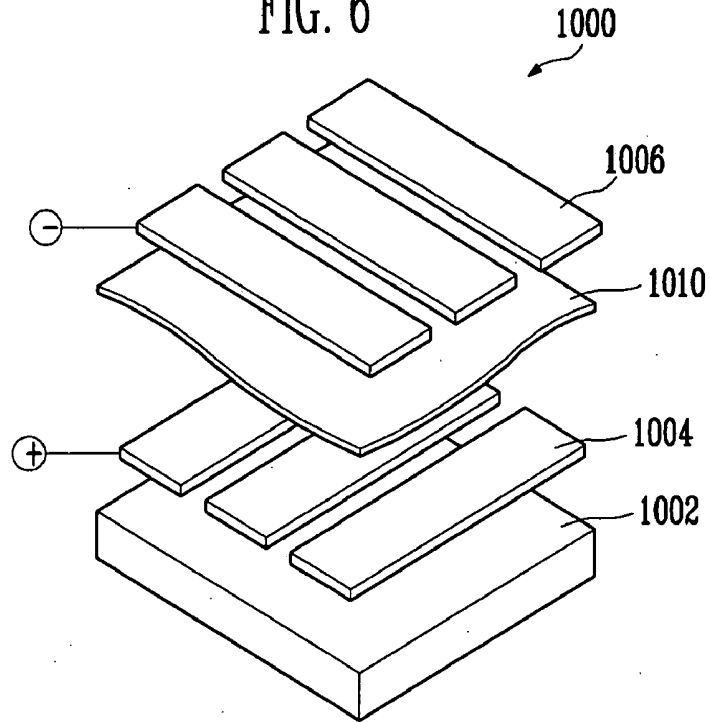

FIG. 7

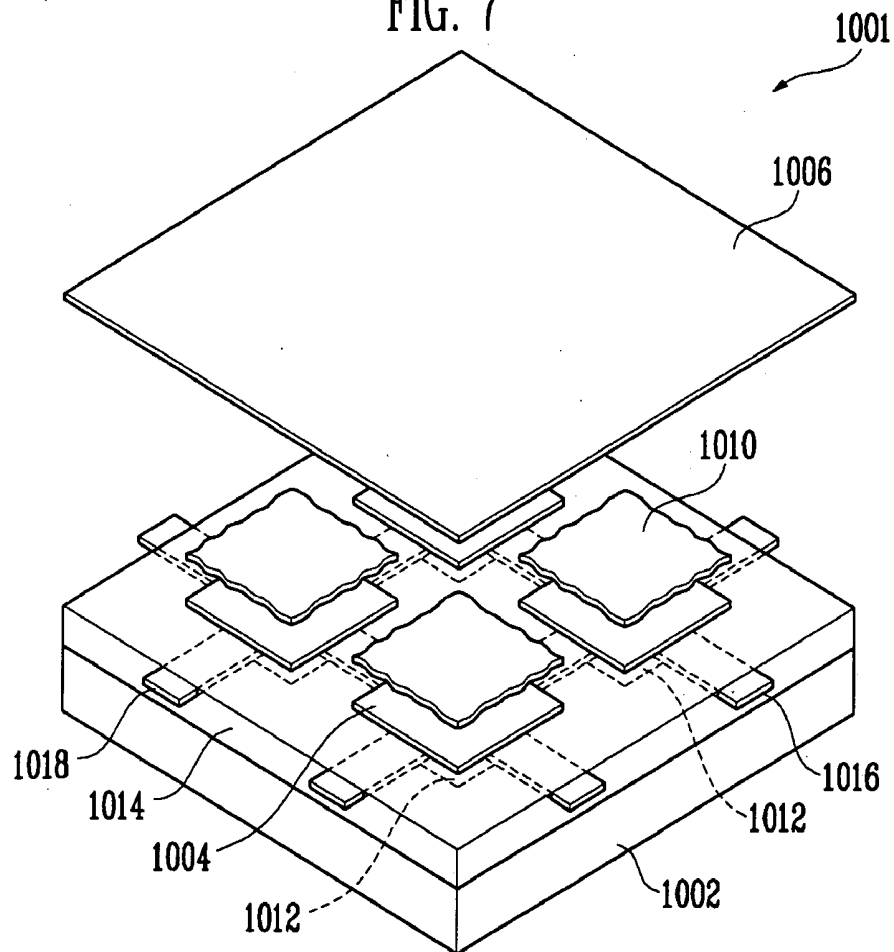

FIG. 8

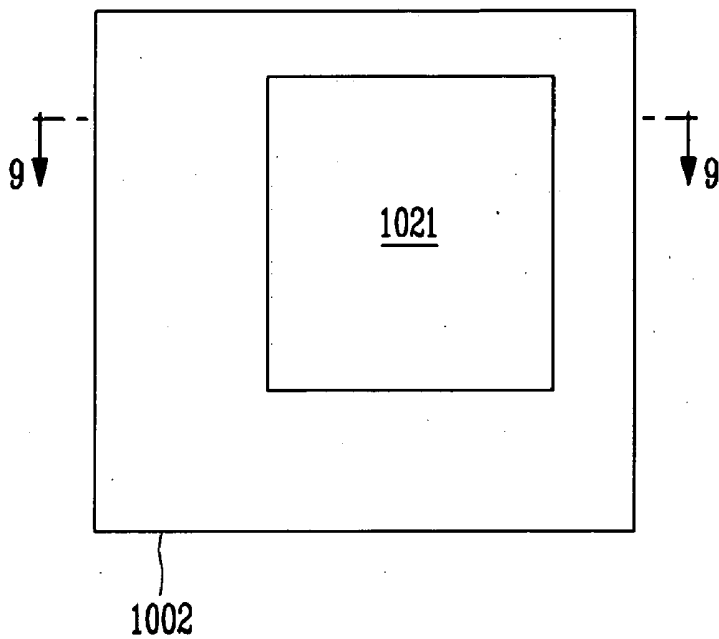

FIG. 9

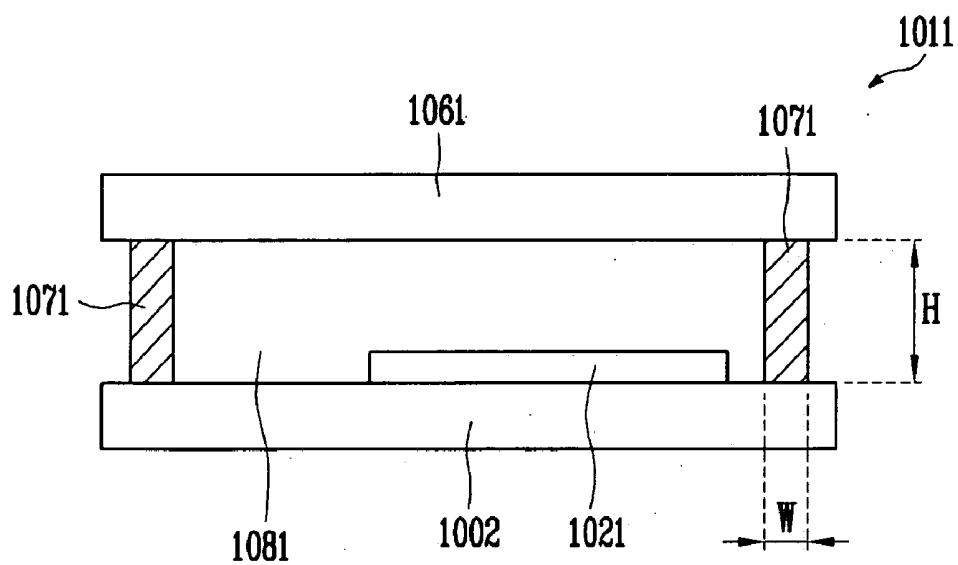
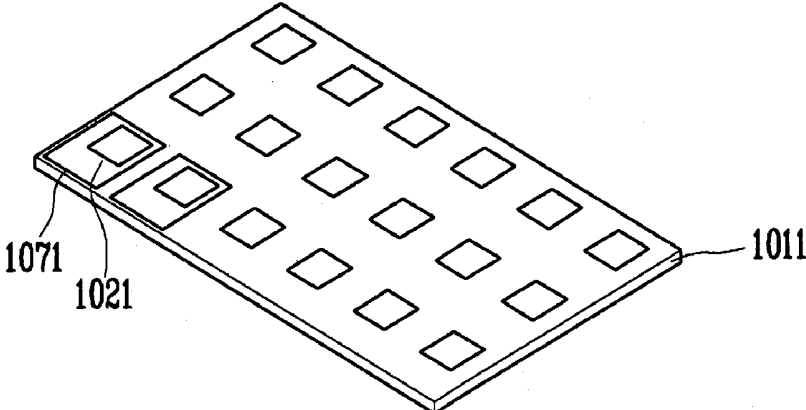

FIG. 10



**ORGANIC LIGHT EMITTING DISPLAY
DEVICE AND A METHOD OF
MANUFACTURING THEREOF**

CROSS-REFERENCE TO RELATED
APPLICATIONS

[0001] This application claims the benefit of Korean Patent Application No. 10-2006-0008768, filed on Jan. 27, 2006, in the Korean Intellectual Property Office, the disclosure of which is incorporated herein by reference in its entirety. This application is related to and incorporates herein by reference the entire contents of the following concurrently filed application:

Title	Atty. Docket No.	Filing Date	Application No.
ORGANIC LIGHT EMITTING DISPLAY DEVICE AND A METHOD OF MANUFACTURING THEREOF	SDISHN.050AUS		

BACKGROUND

[0002] 1. Field

[0003] The invention relates to an organic light emitting display device and a method of manufacturing the same.

[0004] 2. Discussion of the Related Technology

[0005] Generally, an organic light emitting display device is composed of a substrate providing a pixel region and a non-pixel region; a container or a substrate arranged to face the substrate for its encapsulation and coalesced into the substrate using a sealant such as epoxy.

[0006] A plurality of light emitting elements connected between scan lines and data lines in a matrix arrangement are formed in a pixel region of the substrate. The light emitting elements are composed of an anode electrode; a cathode electrode; and an organic thin film layer formed between the anode electrode and the cathode electrode. The organic layer can include a hole transport layer, an organic emitting layer and an electron transport layer.

[0007] However, the light emitting element, configured as described above, is susceptible to hydrogen or oxygen since it includes organic substances. The elements are also easily oxidized by moisture in the air since a cathode electrode is generally formed of metallic materials and therefore its electrical and light-emission properties are subject to deterioration. Accordingly, moisture penetrated from the outside should be excluded and removed in order to inhibit this deterioration by loading a container manufactured in a form of a metallic can or cup, and a substrate such as glass, plastic, etc. with a moisture absorbent in a powdery form or adhering the moisture absorbent, in a form of film, to the container.

[0008] However, the above method for loading a container with a moisture absorbent in a powdery form has disadvantages in that its process is complex, the material and manufacturing cost is expensive, a resulting display device is thick, and it is difficult to apply to a top emission display. In addition, the above method for adhering the moisture absorbent, in a form of film, to the container has disadvantages in that it is difficult to remove moisture and its mass-production

is difficult due to low durability and reliability. The above is simply to describe generally the field of organic light emitting displays and is not an admission of prior art.

[0009] In order to solve the problems, various methods for encapsulating a light emitting element by forming a side wall with a frit have been disclosed.

[0010] International Patent application No. PCT/KR2002/000994 (May 24, 2002) discloses an encapsulation container having a side wall formed of a glass frit; and a method of manufacturing the same.

[0011] Korean Patent Publication No. 2001-0084380 (Sep. 6, 2001) discloses a method for encapsulating a frit frame using a laser.

[0012] Korean Patent Publication No. 2002-0051153 (Jun. 28, 2002) discloses a packaging method for encapsulating an upper substrate and a lower substrate with a frit using a laser.

SUMMARY OF CERTAIN INVENTIVE
ASPECTS

[0013] An aspect of the invention provides an organic light emitting device, which may comprise: a first substrate defining a pixel region and a non-pixel region; an array of organic light emitting pixels formed over the pixel region of the first substrate; a second substrate placed over the first substrate, the array being interposed between the first and second substrates; a frit seal comprising a plurality of elongated segments interposed between the first and second substrates, the plurality of elongated segments in combination surrounding the array such that the array is encapsulated by the first substrate, the second substrate and the frit seal, the plurality of elongated segments comprising a first elongated segment elongated generally in a first direction; and a scan driver formed over the non-pixel region of the first substrate, wherein the scan driver overlaps with the first elongated segment when viewed in a second direction from the first or second substrate, wherein the shortest distance between the first and second substrates is defined in the second direction.

[0014] In the foregoing device, the first elongated segment may substantially eclipse the scan driver. The scan driver may substantially eclipse the first elongated segment. The frit may not overlap the scan driver in its entirety. The scan driver may extend generally in the first direction parallel to the first elongated segment. The first elongated segment may overlap a portion of the scan driver facing the array. The portion may be elongated generally in the first direction. The portion may have a width defined in a third direction perpendicular to the first and second directions, and wherein the width may be from about 0.05 mm to about 1.0 mm. The scan driver may have a width defined in a third direction perpendicular to the first and second directions, wherein the width may be from about 0.2 mm to about 1.5 mm. The scan driver comprises a wiring area, and wherein the first elongated segment may overlap with the wiring area when viewed in the second direction. The scan driver may comprise an active area, and wherein the first elongated segment may overlap with the active area when viewed in the second direction.

[0015] Still in the foregoing method, the device may further comprise an electrically conductive layer formed between the first elongated segment and the scan driver. The array may comprise an anode, and wherein the electrically conductive layer may be deposited simultaneously with the anode. The electrically conductive layer may be reflective

with respect to a laser beam or infrared beam. The device may further comprise a planarization layer formed between the first substrate and the frit, and wherein the scan driver may be substantially buried in the planarization layer. The scan driver may comprise an integrated circuit comprising a thin film transistor. The frit seal may comprise one or more materials selected from the group consisting of magnesium oxide (MgO), calcium oxide (CaO), barium oxide (BaO), lithium oxide (Li₂O), sodium oxide (Na₂O), potassium oxide (K₂O), boron oxide (B₂O₃), vanadium oxide (V₂O₅), zinc oxide (ZnO), tellurium oxide (TeO₂), aluminum oxide (Al₂O₃), silicon dioxide (SiO₂), lead oxide (PbO), tin oxide (SnO), phosphorous oxide (P₂O₅), ruthenium oxide (Ru₂O), rubidium oxide (Rb₂O), rhodium oxide (Rh₂O), ferrite oxide (Fe₂O₃), copper oxide (CuO), titanium oxide (TiO₂), tungsten oxide (WO₃), bismuth oxide (Bi₂O₃), antimony oxide (Sb₂O₃), lead-borate glass, tin-phosphate glass, vanadate glass, and borosilicate.

[0016] Another aspect of the invention provides a method of making an organic light emitting device, which may comprise: providing a first substrate defining a pixel region and a non-pixel region; forming an array of organic light emitting pixels over the pixel region of the first substrate; forming a scan driver over the non-pixel region of the first substrate; arranging a second substrate over the first substrate such that the array being interposed between the first and second substrates; interposing a frit comprising a plurality of elongated segments between the first substrate and second substrate, the plurality of elongated segments in combination surrounding the array, and the plurality of elongated segments comprising a first elongated segment elongated generally in a first direction; and wherein the scan driver overlaps with the first elongated segment when viewed in a second direction from the first or second substrate, wherein the shortest distance between the first and second substrates is defined in the second direction. In the foregoing method, the first elongated segment may substantially eclipse the scan driver. An electrically conductive layer may be interposed between the first elongated segment and the scan driver.

[0017] In a method for encapsulating a light emitting element with a frit used herein, a sealing substrate coated with the frit can be coalesced into the substrate in which the light emitting element is formed, and then the frit can be melted and adhered to the substrate by irradiating a laser in the back surface of the sealing substrate.

[0018] Accordingly, aspects of the invention provide an organic light emitting display device capable of reducing a dead space by forming a frit so that the frit can be overlapped with a scan driver and inhibiting the scan driver from being damaged upon irradiating a laser to the frit by forming a metal film in a region corresponding to the scan driver; and a method of manufacturing the same.

[0019] The foregoing and/or other aspects of the invention provides an organic light emitting display device including a first substrate defining a pixel region and a non-pixel region, wherein an organic light emitting element composed of a first electrode, an organic thin film layer and a second electrode is formed in the pixel region and a scan driver and a metal film corresponding to a region of the scan driver are formed in the non-pixel region; a second substrate sealed spaced apart from the pixel region and the non-pixel region of the first substrate; and a frit formed along an edge of a non-pixel region of the second substrate, wherein the frit is

formed so that it can be overlapped with an active area of the scan driver formed in the non-pixel region.

[0020] The foregoing and/or another aspects of the invention provides a method for manufacturing an organic light emitting display device, including steps of providing an organic light emitting element composed of a first electrode, an organic thin film layer and a second electrode in the pixel region of the first substrate divided into a pixel region and a non-pixel region and providing a scan driver and a metal film corresponding to a region of the scan driver in the non-pixel region; forming a frit along an edge of a region, which corresponds to the scan driver of the non-pixel region of the first substrate, in a second substrate sealed spaced apart a predetermined distance from the first substrate; arranging the second substrate on the first substrate so that the frit formed in the second substrate can be overlapped with an active area of the scan driver which is a non-pixel region of the first substrate; and adhering the first substrate to the second substrate by irradiating a laser beam to the frit in the back surface of the second substrate.

[0021] Further embodiments provide a method of making an organic light emitting device, the method comprising providing an unfinished device comprising a first substrate, an array of organic light emitting pixels formed over the first substrate, and an electrically conductive line formed over the first substrate, further providing a second substrate, interposing a frit between the first and second substrates such that the array is interposed between the first and second substrates and such that the frit surrounds the array, arranging the second substrate on the first substrate so that the frit overlaps with an active area of a scan driver in the non-pixel region of the first substrate, and melting and resolidifying at least part of the frit so as to interconnect the unfinished device and the second substrate via the frit.

BRIEF DESCRIPTION OF THE DRAWINGS

[0022] These and other aspects and advantages of the invention will become apparent and more readily appreciated from the following description of the embodiments, taken in conjunction with the accompanying drawings of which:

[0023] FIG. 1 is a plan view showing one embodiment of an organic light emitting display device;

[0024] FIG. 2 is a cross-sectional view taken from a line I-I' of the FIG. 1;

[0025] FIG. 3 is a plane view showing one embodiment of an organic light emitting display device;

[0026] FIG. 4 is a cross-sectional view taken from a line II-II' of the FIG. 3; and

[0027] FIG. 5 is a cross-sectional view taken from a line III-III' of the FIG. 3.

[0028] FIG. 6 is a schematic exploded view of a passive matrix type organic light emitting display device in accordance with one embodiment.

[0029] FIG. 7 is a schematic exploded view of an active matrix type organic light emitting display device in accordance with one embodiment.

[0030] FIG. 8 is a schematic top plan view of an organic light emitting display in accordance with one embodiment.

[0031] FIG. 9 is a cross-sectional view of the organic light emitting display of FIG. 8, taken along the line 9-9.

[0032] FIG. 10 is a schematic perspective view illustrating mass production of organic light emitting devices in accordance with one embodiment.

DETAILED DESCRIPTION OF CERTAIN EMBODIMENTS

[0033] Hereinafter, embodiments according to the invention will be described in detail with reference to the accompanying drawings. Therefore, the description proposed herein is just one example for the purpose of illustrations only, not intended to limit the scope of the invention, so it should be understood that other equivalents and modifications could be made thereto without departing from the spirit and scope of the invention, as apparent to those skilled in the art.

[0034] An organic light emitting display (OLED) is a display device comprising an array of organic light emitting diodes. Organic light emitting diodes are solid state devices which include an organic material and are adapted to generate and emit light when appropriate electrical potentials are applied.

[0035] OLEDs can be generally grouped into two basic types dependent on the arrangement with which the stimulating electrical current is provided. FIG. 6 schematically illustrates an exploded view of a simplified structure of a passive matrix type OLED 1000. FIG. 7 schematically illustrates a simplified structure of an active matrix type OLED 1001. In both configurations, the OLED 1000, 1001 includes OLED pixels built over a substrate 1002, and the OLED pixels include an anode 1004, a cathode 1006 and an organic layer 1010. When an appropriate electrical current is applied to the anode 1004, electric current flows through the pixels and visible light is emitted from the organic layer.

[0036] Referring to FIG. 6, the passive matrix OLED (PMOLED) design includes elongate strips of anode 1004 arranged generally perpendicular to elongate strips of cathode 1006 with organic layers interposed therebetween. The intersections of the strips of cathode 1006 and anode 1004 define individual OLED pixels where light is generated and emitted upon appropriate excitation of the corresponding strips of anode 1004 and cathode 1006. PMOLEDs provide the advantage of relatively simple fabrication.

[0037] Referring to FIG. 7, the active matrix OLED (AMOLED) includes driving circuits 1012 arranged between the substrate 1002 and an array of OLED pixels. An individual pixel of AMOLEDs is defined between the common cathode 1006 and an anode 1004, which is electrically isolated from other anodes. Each driving circuit 1012 is coupled with an anode 1004 of the OLED pixels and further coupled with a data line 1016 and a scan line 1018. In embodiments, the scan lines 1018 supply scan signals that select rows of the driving circuits, and the data lines 1016 supply data signals for particular driving circuits. The data signals and scan signals stimulate the local driving circuits 1012, which excite the anodes 1004 so as to emit light from their corresponding pixels.

[0038] In the illustrated AMOLED, the local driving circuits 1012, the data lines 1016 and scan lines 1018 are buried in a planarization layer 1014, which is interposed between the pixel array and the substrate 1002. The planarization layer 1014 provides a planar top surface on which the organic light emitting pixel array is formed. The planarization layer 1014 may be formed of organic or inorganic materials, and formed of two or more layers although shown

as a single layer. The local driving circuits 1012 are typically formed with thin film transistors (TFT) and arranged in a grid or array under the OLED pixel array. The local driving circuits 1012 may be at least partly made of organic materials, including organic TFT. AMOLEDs have the advantage of fast response time improving their desirability for use in displaying data signals. Also, AMOLEDs have the advantages of consuming less power than passive matrix OLEDs.

[0039] Referring to common features of the PMOLED and AMOLED designs, the substrate 1002 provides structural support for the OLED pixels and circuits. In various embodiments, the substrate 1002 can comprise rigid or flexible materials as well as opaque or transparent materials, such as plastic, glass, and/or foil. As noted above, each OLED pixel or diode is formed with the anode 1004, cathode 1006 and organic layer 1010 interposed therebetween. When an appropriate electrical current is applied to the anode 1004, the cathode 1006 injects electrons and the anode 1004 injects holes. In certain embodiments, the anode 1004 and cathode 1006 are inverted; i.e., the cathode is formed on the substrate 1002 and the anode is oppositely arranged.

[0040] Interposed between the cathode 1006 and anode 1004 are one or more organic layers. More specifically, at least one emissive or light emitting layer is interposed between the cathode 1006 and anode 1004. The light emitting layer may comprise one or more light emitting organic compounds. Typically, the light emitting layer is configured to emit visible light in a single color such as blue, green, red or white. In the illustrated embodiment, one organic layer 1010 is formed between the cathode 1006 and anode 1004 and acts as a light emitting layer. Additional layers, which can be formed between the anode 1004 and cathode 1006, can include a hole transporting layer, a hole injection layer, an electron transporting layer and an electron injection layer.

[0041] Hole transporting and/or injection layers can be interposed between the light emitting layer 1010 and the anode 1004. Electron transporting and/or injecting layers can be interposed between the cathode 1006 and the light emitting layer 1010. The electron injection layer facilitates injection of electrons from the cathode 1006 toward the light emitting layer 1010 by reducing the work function for injecting electrons from the cathode 1006. Similarly, the hole injection layer facilitates injection of holes from the anode 1004 toward the light emitting layer 1010. The hole and electron transporting layers facilitate movement of the carriers injected from the respective electrodes toward the light emitting layer.

[0042] In some embodiments, a single layer may serve both electron injection and transportation functions or both hole injection and transportation functions. In some embodiments, one or more of these layers are lacking. In some embodiments, one or more organic layers are doped with one or more materials that help injection and/or transportation of the carriers. In embodiments where only one organic layer is formed between the cathode and anode, the organic layer may include not only an organic light emitting compound but also certain functional materials that help injection or transportation of carriers within that layer.

[0043] There are numerous organic materials that have been developed for use in these layers including the light emitting layer. Also, numerous other organic materials for use in these layers are being developed. In some embodiments, these organic materials may be macromolecules including oligomers and polymers. In some embodiments,

the organic materials for these layers may be relatively small molecules. The skilled artisan will be able to select appropriate materials for each of these layers in view of the desired functions of the individual layers and the materials for the neighboring layers in particular designs.

[0044] In operation, an electrical circuit provides appropriate potential between the cathode 1006 and anode 1004. This results in an electrical current flowing from the anode 1004 to the cathode 1006 via the interposed organic layer(s). In one embodiment, the cathode 1006 provides electrons to the adjacent organic layer 1010. The anode 1004 injects holes to the organic layer 1010. The holes and electrons recombine in the organic layer 1010 and generate energy particles called "excitons." The excitons transfer their energy to the organic light emitting material in the organic layer 1010, and the energy is used to emit visible light from the organic light emitting material. The spectral characteristics of light generated and emitted by the OLED 1000, 1001 depend on the nature and composition of organic molecules in the organic layer(s). The composition of the one or more organic layers can be selected to suit the needs of a particular application by one of ordinary skill in the art.

[0045] OLED devices can also be categorized based on the direction of the light emission. In one type referred to as "top emission" type, OLED devices emit light and display images through the cathode or top electrode 1006. In these embodiments, the cathode 1006 is made of a material transparent or at least partially transparent with respect to visible light. In certain embodiments, to avoid losing any light that can pass through the anode or bottom electrode 1004, the anode may be made of a material substantially reflective of the visible light. A second type of OLED devices emits light through the anode or bottom electrode 1004 and is called "bottom emission" type. In the bottom emission type OLED devices, the anode 1004 is made of a material which is at least partially transparent with respect to visible light. Often, in bottom emission type OLED devices, the cathode 1006 is made of a material substantially reflective of the visible light. A third type of OLED devices emits light in two directions, e.g. through both anode 1004 and cathode 1006. Depending upon the direction(s) of the light emission, the substrate may be formed of a material which is transparent, opaque or reflective of visible light.

[0046] In many embodiments, an OLED pixel array 1021 comprising a plurality of organic light emitting pixels is arranged over a substrate 1002 as shown in FIG. 8. In embodiments, the pixels in the array 1021 are controlled to be turned on and off by a driving circuit (not shown), and the plurality of the pixels as a whole displays information or image on the array 1021. In certain embodiments, the OLED pixel array 1021 is arranged with respect to other components, such as drive and control electronics to define a display region and a non-display region. In these embodiments, the display region refers to the area of the substrate 1002 where OLED pixel array 1021 is formed. The non-display region refers to the remaining areas of the substrate 1002. In embodiments, the non-display region can contain logic and/or power supply circuitry. It will be understood that there will be at least portions of control/drive circuit elements arranged within the display region. For example, in PMOLEDs, conductive components will extend into the display region to provide appropriate potential to the anode and cathodes. In AMOLEDs, local driving circuits and

data/scan lines coupled with the driving circuits will extend into the display region to drive and control the individual pixels of the AMOLEDs.

[0047] One design and fabrication consideration in OLED devices is that certain organic material layers of OLED devices can suffer damage or accelerated deterioration from exposure to water, oxygen or other harmful gases. Accordingly, it is generally understood that OLED devices be sealed or encapsulated to inhibit exposure to moisture and oxygen or other harmful gases found in a manufacturing or operational environment. FIG. 9 schematically illustrates a cross-section of an encapsulated OLED device 1011 having a layout of FIG. 8 and taken along the line 9-9 of FIG. 8. In this embodiment, a generally planar top plate or substrate 1061 engages with a seal 1071 which further engages with a bottom plate or substrate 1002 to enclose or encapsulate the OLED pixel array 1021. In other embodiments, one or more layers are formed on the top plate 1061 or bottom plate 1002, and the seal 1071 is coupled with the bottom or top substrate 1002, 1061 via such a layer. In the illustrated embodiment, the seal 1071 extends along the periphery of the OLED pixel array 1021 or the bottom or top plate 1002, 1061.

[0048] In embodiments, the seal 1071 is made of a frit material as will be further discussed below. In various embodiments, the top and bottom plates 1061, 1002 comprise materials such as plastics, glass and/or metal foils which can provide a barrier to passage of oxygen and/or water to thereby protect the OLED pixel array 1021 from exposure to these substances. In embodiments, at least one of the top plate 1061 and the bottom plate 1002 are formed of a substantially transparent material.

[0049] To lengthen the life time of OLED devices 1011, it is generally desired that seal 1071 and the top and bottom plates 1061, 1002 provide a substantially non-permeable seal to oxygen and water vapor and provide a substantially hermetically enclosed space 1081. In certain applications, it is indicated that the seal 1071 of a frit material in combination with the top and bottom plates 1061, 1002 provide a barrier to oxygen of less than approximately 10^{-3} cc/m²-day and to water of less than 10^{-6} g/m²-day. Given that some oxygen and moisture can permeate into the enclosed space 1081, in some embodiments, a material that can take up oxygen and/or moisture is formed within the enclosed space 1081.

[0050] The seal 1071 has a width W, which is its thickness in a direction parallel to a surface of the top or bottom substrate 1061, 1002 as shown in FIG. 9. The width varies among embodiments and ranges from about 300 μ m to about 3000 μ m, optionally from about 500 μ m to about 1500 μ m. Also, the width may vary at different positions of the seal 1071. In some embodiments, the width of the seal 1071 may be the largest where the seal 1071 contacts one of the bottom and top substrate 1002, 1061 or a layer formed thereon. The width may be the smallest where the seal 1071 contacts the other. The width variation in a single cross-section of the seal 1071 relates to the cross-sectional shape of the seal 1071 and other design parameters.

[0051] The seal 1071 has a height H, which is its thickness in a direction perpendicular to a surface of the top or bottom substrate 1061, 1002 as shown in FIG. 9. The height varies among embodiments and ranges from about 2 μ m to about 30 μ m, optionally from about 10 μ m to about 15 μ m. Generally, the height does not significantly vary at different

positions of the seal 1071. However, in certain embodiments, the height of the seal 1071 may vary at different positions thereof.

[0052] In the illustrated embodiment, the seal 1071 has a generally rectangular cross-section. In other embodiments, however, the seal 1071 can have other various cross-sectional shapes such as a generally square cross-section, a generally trapezoidal cross-section, a cross-section with one or more rounded edges, or other configuration as indicated by the needs of a given application. To improve hermeticity, it is generally desired to increase the interfacial area where the seal 1071 directly contacts the bottom or top substrate 1002, 1061 or a layer formed thereon. In some embodiments, the shape of the seal can be designed such that the interfacial area can be increased.

[0053] The seal 1071 can be arranged immediately adjacent the OLED array 1021, and in other embodiments, the seal 1071 is spaced some distance from the OLED array 1021. In certain embodiment, the seal 1071 comprises generally linear segments that are connected together to surround the OLED array 1021. Such linear segments of the seal 1071 can extend, in certain embodiments, generally parallel to respective boundaries of the OLED array 1021. In other embodiment, one or more of the linear segments of the seal 1071 are arranged in a non-parallel relationship with respective boundaries of the OLED array 1021. In yet other embodiments, at least part of the seal 1071 extends between the top plate 1061 and bottom plate 1002 in a curvilinear manner.

[0054] As noted above, in certain embodiments, the seal 1071 is formed using a frit material or simply "frit" or glass frit," which includes fine glass particles. The frit particles includes one or more of magnesium oxide (MgO), calcium oxide (CaO), barium oxide (BaO), lithium oxide (Li₂O), sodium oxide (Na₂O), potassium oxide (K₂O), boron oxide (B₂O₃), vanadium oxide (V₂O₅), zinc oxide (ZnO), tellurium oxide (TeO₂), aluminum oxide (Al₂O₃), silicon dioxide (SiO₂), lead oxide (PbO), tin oxide (SnO), phosphorous oxide (P₂O₅), ruthenium oxide (Ru₂O), rubidium oxide (Rb₂O), rhodium oxide (Rh₂O), ferrite oxide (Fe₂O₃), copper oxide (CuO), titanium oxide (TiO₂), tungsten oxide (WO₃), bismuth oxide (Bi₂O₃), antimony oxide (Sb₂O₃), lead-borate glass, tin-phosphate glass, vanadate glass, and borosilicate, etc. In embodiments, these particles range in size from about 2 μm to about 30 μm, optionally about 5 μm to about 10 μm, although not limited only thereto. The particles can be as large as about the distance between the top and bottom substrates 1061, 1002 or any layers formed on these substrates where the frit seal 1071 contacts.

[0055] The frit material used to form the seal 1071 can also include one or more filler or additive materials. The filler or additive materials can be provided to adjust an overall thermal expansion characteristic of the seal 1071 and/or to adjust the absorption characteristics of the seal 1071 for selected frequencies of incident radiant energy. The filler or additive material(s) can also include inversion and/or additive fillers to adjust a coefficient of thermal expansion of the frit. For example, the filler or additive materials can include transition metals, such as chromium (Cr), iron (Fe), manganese (Mn), cobalt (Co), copper (Cu), and/or vanadium. Additional materials for the filler or additives include ZnSiO₄, PbTiO₃, ZrO₂, eucryptite.

[0056] In embodiments, a frit material as a dry composition contains glass particles from about 20 to 90 about wt %,

and the remaining includes fillers and/or additives. In some embodiments, the frit paste contains about 10-30 wt % organic materials and about 70-90% inorganic materials. In some embodiments, the frit paste contains about 20 wt % organic materials and about 80 wt % inorganic materials. In some embodiments, the organic materials may include about 0-30 wt % binder(s) and about 70-100 wt % solvent(s). In some embodiments, about 10 wt % is binder(s) and about 90 wt % is solvent(s) among the organic materials. In some embodiments, the inorganic materials may include about 0-10 wt % additives, about 20-40 wt % fillers and about 50-80 wt % glass powder. In some embodiments, about 0-5 wt % is additive(s), about 25-30 wt % is filler(s) and about 65-75 wt % is the glass powder among the inorganic materials.

[0057] In forming a frit seal, a liquid material is added to the dry frit material to form a frit paste. Any organic or inorganic solvent with or without additives can be used as the liquid material. In embodiments, the solvent includes one or more organic compounds. For example, applicable organic compounds are ethyl cellulose, nitro cellulose, hydroxypropyl cellulose, butyl carbitol acetate, terpineol, butyl cellulose, acrylate compounds. Then, the thus formed frit paste can be applied to form a shape of the seal 1071 on the top and/or bottom plate 1061, 1002.

[0058] In one exemplary embodiment, a shape of the seal 1071 is initially formed from the frit paste and interposed between the top plate 1061 and the bottom plate 1002. The seal 1071 can in certain embodiments be pre-cured or pre-sintered to one of the top plate and bottom plate 1061, 1002. Following assembly of the top plate 1061 and the bottom plate 1002 with the seal 1071 interposed therebetween, portions of the seal 1071 are selectively heated such that the frit material forming the seal 1071 at least partially melts. The seal 1071 is then allowed to resolidify to form a secure joint between the top plate 1061 and the bottom plate 1002 to thereby inhibit exposure of the enclosed OLED pixel array 1021 to oxygen or water.

[0059] In embodiments, the selective heating of the frit seal is carried out by irradiation of light, such as a laser or directed infrared lamp. As previously noted, the frit material forming the seal 1071 can be combined with one or more additives or filler such as species selected for improved absorption of the irradiated light to facilitate heating and melting of the frit material to form the seal 1071.

[0060] In some embodiments, OLED devices 1011 are mass produced. In an embodiment illustrated in FIG. 10, a plurality of separate OLED arrays 1021 is formed on a common bottom substrate 1101. In the illustrated embodiment, each OLED array 1021 is surrounded by a shaped frit to form the seal 1071. In embodiments, common top substrate (not shown) is placed over the common bottom substrate 1101 and the structures formed thereon such that the OLED arrays 1021 and the shaped frit paste are interposed between the common bottom substrate 1101 and the common top substrate. The OLED arrays 1021 are encapsulated and sealed, such as via the previously described enclosure process for a single OLED display device. The resulting product includes a plurality of OLED devices kept together by the common bottom and top substrates. Then, the resulting product is cut into a plurality of pieces, each of which constitutes an OLED device 1011 of FIG. 9. In certain embodiments, the individual OLED devices 1011 then further undergo additional packaging operations to further

improve the sealing formed by the frit seal 1071 and the top and bottom substrates 1061, 1002.

[0061] FIG. 1 is a plan view showing an organic light emitting display device. FIG. 2 is a cross-sectional view taken from a line I-I' of the FIG. 1.

[0062] As shown in FIG. 1 and FIG. 2, an organic light emitting display device is composed of a deposition substrate 10, an encapsulation substrate 20 and a frit 30. The deposition substrate 10 is a substrate including a pixel region 11 including at least one organic light emitting element; and a non-pixel region 15 formed in a circumference of the pixel region 11, and the encapsulation substrate 20 is adhered against a surface in which an organic light emitting element 16 of the deposition substrate 10 is formed. Here, drives such as a scan driver 12 and a data driver 13 are formed in the non-pixel region 15 of the deposition substrate 10, respectively.

[0063] In order to adhere the deposition substrate 10 to the encapsulation substrate 20, the frit 30 is applied along edges of the deposition substrate 10 and the encapsulation substrate 20, and the frit 30 is also cured using methods such as irradiation of a laser beam or an ultraviolet ray, etc. Here, the frit 30 is applied such that hydrogen, oxygen, moisture, etc. that penetrate between a fine gap are obstructed since an encapsulating material is formed additionally.

[0064] Meanwhile, in one embodiment, the organic light emitting display device has a scan driver width (0.4 mm) and a signal line width (0.3 mm) formed in a non-pixel region 15; and a frit width (0.7 mm) 30 formed in a region of a seal of width (1.5 mm) 14 between the pixel region 11 and the non-pixel region 15. Here, an active area of the scan driver has a width of approximately 0.15 mm, and a wiring area of the scan driver has a width of approximately 0.25 mm.

[0065] However, if in the non-pixel region a dead space region is formed in a wide range as described above, then the organic light emitting display device has a disadvantage that quality of the products is deteriorated due to its increase size.

[0066] FIG. 3 is a plan view showing one embodiment of an organic light emitting display device. As shown in FIG. 3, an organic light emitting display device is divided into a pixel region 210 and a non-pixel region 220, wherein an organic light emitting element composed of a first electrode, an organic thin film layer and a second electrode is formed in the pixel region 210. The non-pixel region 220 includes a first substrate 200 in which a scan driver 410 and a metal film 108b corresponding to a region of the scan driver are formed. A second substrate 300 is sealed and spaced apart a predetermined distance from the pixel region 210 and the non-pixel region 220 of the first substrate 200. A frit 320 is formed in spaced gaps of the non-pixel regions of the first substrate 200 and the second substrate 300 and formed so that it can be overlapped with an active area of a scan driver 410 of the first substrate 200.

[0067] The first substrate 200 of the organic light emitting display device is referred to as a pixel region 210 and a non-pixel region 220 surrounding the pixel region 210. In the pixel region 210 of the first substrate 200 are formed a plurality of organic light emitting elements 100 connected between a scan line 104b and a data line 106c in a matrix arrangement. In the non-pixel region 220 of the first substrate 200 are formed a scan line 104b and a data line 106c extending from the scan line 104b and the data line 106c of the pixel region 210. A power supply line (not shown) for operating an organic light emitting element 100 and a scan

drive unit 410 and a data drive unit 420 for treating signals are provided from the outside through pads 104c and 106d, to supply the signals to the scan line 104b and the data line 106c.

[0068] FIG. 4 is a cross-sectional view taken from a line II-II' in which a metal film and a scan driver are not illustrated. As shown in FIG. 4, the organic light emitting element 100 formed in the pixel region is composed of an anode electrode 108a as a first electrode, a cathode electrode 111 as a second electrode, and an organic thin film layer 110 formed between the anode electrode 108a and the cathode electrode 111. The organic thin film layer 110 has a structure in which a hole transport layer, an organic emitting layer and an electron transport layer are laminated, and may further include a hole injection layer and an electron injection layer. In addition, the organic thin film layer 110 may further include a switching transistor for controlling an operation of the organic light emitting diode 100, and a capacitor for sustaining signals.

[0069] Hereinafter, one embodiment of a process of manufacturing an organic light emitting element 100 will be described in detail, as follows. A buffer layer 101 is formed on a substrate 200 of a pixel region 210 and a non-pixel region 220. The buffer layer 101 inhibits the substrate 200 from being damaged by heat and obstructs ions from being diffused from the substrate 200. The buffer layer 101 can be formed of insulation films such as a silicon oxide film (SiO₂) and/or a silicon nitride film (SiN_x).

[0070] A semiconductor layer 102 can be provided with an active layer and be formed in a predetermined region on the buffer layer 101 of the pixel region 210. A gate insulation film 103 can be formed in the upper surface of the pixel region 210 including the semiconductor layer 102.

[0071] A gate electrode 104a is formed on the gate insulation film 103 in the upper portion of the semiconductor layer 102. In the pixel region 210 is formed a scan line 104b connected with the gate electrode 104a. In the non-pixel region 220 are formed a scan line 104b extended from the scan line 104b of the pixel region 210; and a pad 104c for receiving signals from the outside. In one embodiment the gate electrode 104a, the scan line 104b and the pad 104c comprise metals such as molybdenum (Mo), tungsten (W), titanium (Ti), aluminum (Al), etc., alloys thereof, and/or formed with a laminated structure.

[0072] An interlayer insulation film 105 is formed on upper surfaces of the pixel region 210 and the non-pixel region 220 which include the gate electrode 104a, respectively. The interlayer insulation film 105 and the gate insulation film 103 are patterned to form a contact hole so as to expose a region of the semiconductor layer 102. Source and drain electrodes 106a and 106b are formed so that they can be connected with the semiconductor layer 102 through the contact hole. In the pixel region 210 is formed a data line 106c connected with the source and drain electrodes 106a and 106b. In the non-pixel region 220 is formed a data line 106c extended from the data line 106c of the pixel region 210 and a pad 106d for receiving signals from the outside. The source and drain electrodes 106a and 106b, the data line 106c and the pad 106d comprise metals such as molybdenum (Mo), tungsten (W), titanium (Ti), aluminum (Al), etc., alloys thereof, and/or are formed with a laminated structure.

[0073] An overcoat 107 is formed on upper surfaces of the pixel region 210 and the non-pixel region 220 to flatten the surfaces. The overcoat 107 of the pixel region 210 is

patterned to form a via hole so as to expose a region of the source or drain electrodes **106a** or **106b**. An anode electrode **108** is forced to connect with the source or drain electrodes **106a** or **106b** through the via hole.

[0074] An organic thin film layer **110** is formed on the overcoat **107** so as to expose some region of the anode electrode **108a**. An organic thin film layer **110** is formed on the exposed anode electrode **108a** and a cathode electrode **111** is formed on a pixel definition layer **109** including the organic thin film layer **110**.

[0075] A metal film **108b** is formed by depositing metallic materials such as the anode electrode **108a** onto an overcoat **107** of the non-pixel region **220** when forming the anode electrode **108a**. The metal film **108b** is formed to the extent of an active area, a wiring area and a signal line area of the scan driver to correspond to a region in which the frit **320** is formed.

[0076] A sealing substrate is formed having a suitable size so that the second substrate **300** can be overlapped with some regions of the pixel region **210** and the non-pixel region **220**. A substrate composed of transparent materials such as glass may be used as the second substrate **300**. In certain embodiments, substrate comprises silicon oxide (SiO_2).

[0077] FIG. 5 is a cross-sectional view taken from a line III-III', in which the scan driver is not illustrated. As shown in FIG. 5, a frit **320** for encapsulation is formed along an edge of the second substrate **300** corresponding to the non-pixel region **220**. Here, the frit **320** has a width of approximately 0.7 mm, and is formed so that it can be overlapped with an active area of the scan driver **410**.

[0078] More specifically, the scan driver **410** in the non-pixel region **220** includes an active area, a scan driver wiring area and a signal line, and therefore the scan driver **410** has a width of approximately 0.7 mm. The active area of the scan driver has a width of approximately 0.15 mm, the scan driver wiring area has a width of approximately 0.25 mm, and the signal line has a width of approximately 0.3 mm.

[0079] The frit **320** is formed so that its width (0.7 mm) can be overlapped with the scan driver by a width of approximately 0.7 mm since the scan driver **410** comprises an active area, a scan driver wiring area and a signal line. The frit **320** is not formed in a region of a seal of width approximately (1.5 mm) **430**, but formed to the extent of the active area of the scan driver. Therefore, a dead space may be reduced by approximately 0.7 mm in the region of the seal **430**. A dead space in another side in which another scan driver is formed is also reduced, and therefore a dead space may be reduced by the total width of approximately 1.4 mm in the both sides. In certain embodiments, the width *W* of the portion overlapped by the scan driver and the frit seal is about 0.05, 0.1, 0.15, 0.2, 0.25, 0.3, 0.35, 0.4, 0.45, 0.5, 0.55, 0.6, 0.65, 0.7, 0.75, 0.8, 0.85, 0.9, 0.95 and 1.0 mm. In some embodiments, the width may be within a range defined by two of the foregoing widths.

[0080] In one embodiment, the frit **320** is formed on a buffer layer **101**, a gate insulation film **103**, an interlayer insulation film **105**, an overcoat **107** and a metal film **108b**, which are extended together with the pixel region **210** and sequentially formed to the extent of the non-pixel region **220**. The scan driver is inhibited from being damaged with the metal film **108b** by reflecting a laser beam or an infrared ray in a region in which the scan driver is formed when the laser beam or the infrared ray is irradiated to the frit **320**. The

frit **320** also inhibits hydrogen, oxygen and moisture from being penetrated by encapsulating the pixel region **210** and is formed to surround some region of the non-pixel region **220** including the pixel region **210**. A reinforcing absorbent may be further formed in an edge region in which the frit **320** is formed.

[0081] The frit **320** can comprise a powdery glass material, but can also comprise a paste. The frit **320** is melted using a laser or an infrared ray. The frit **320** includes in certain embodiments a laser absorbent, an organic binder, and/or a filler for reducing a thermal expansion coefficient. In one embodiment, a paste glass frit **320**, doped with at least one kind of a transition metal using a screen printing or dispensing method, is applied to a height of approximately 14 to 15 μm and a width of approximately 0.6 to 0.7 mm. Moisture and/or organic binder is removed and the frit **320** is plasticized to cure the glass frit.

[0082] The second substrate **300** is arranged on the second substrate **200**, in which the organic light emitting element **100** is formed, so that the second substrate **300** can be overlapped with some regions of the pixel region **210** and the non-pixel region **220**. The frit **320** is melted and adhered to the first substrate **200** by irradiating a laser along the frit **320** in the back surface of the second substrate **300**.

[0083] In one embodiment, the laser beam is irradiated at a power of approximately 36 to 38 W and the laser beam is translocated along the frit **320** at a substantially constant speed. In one embodiment, the laser is scanned at a speed of 10 to 30 mm/sec, and more preferably approximately 20 mm/sec so as to sustain a more uniform melting temperature and adhesive force. The laser beam is preferably not irradiated to patterns such as a metal line on the substrate **200** of the non-pixel region **220** corresponding to the frit **320**.

[0084] In certain embodiments, the frit **320** is formed to encapsulate only a pixel region **210**. In other embodiments, the frit **320** is formed to encapsulate a scan drive unit **410**. In these embodiments, a size of the sealing substrate **300** should be varied accordingly. In certain embodiments, frit **320** is formed in the sealing substrate **300**. In other embodiments, the frit **320** is formed in the substrate **200**. A laser can be used for melting the frit **320** and then adhering it to the substrate **200**, however other power sources such as an infrared ray may also be used.

[0085] As described above, embodiments of the invention are described in detail referring to the accompanying drawings. It should be understood that the terms used in the specification and appended claims should not be construed as limited to general and dictionary meanings, but should be interpreted based on the meanings and concepts corresponding to technical aspects of the invention on the basis of the principle that the inventor is allowed to define terms appropriately for the best explanation. Therefore, the description herein is simply an example for the purpose of illustrations only, and is not intended to limit the scope of the invention. It should be understood that other equivalents and modifications could be made thereto without departing from the spirit and scope of the invention.

What is claimed is:

1. An organic light emitting device comprising:
 - a first substrate defining a pixel region and a non-pixel region;
 - an array of organic light emitting pixels formed over the pixel region of the first substrate;

- a second substrate placed over the first substrate, the array being interposed between the first and second substrates;
- a frit seal comprising a plurality of elongated segments interposed between the first and second substrates, the plurality of elongated segments in combination surrounding the array such that the array is encapsulated by the first substrate, the second substrate and the frit seal, the plurality of elongated segments comprising a first elongated segment elongated generally in a first direction; and
- a scan driver formed over the non-pixel region of the first substrate, wherein the scan driver overlaps with the first elongated segment when viewed in a second direction from the first or second substrate, wherein the shortest distance between the first and second substrates is defined in the second direction.
2. The device of claim 1, wherein the first elongated segment substantially eclipses the scan driver.
 3. The device of claim 1, wherein the scan driver substantially eclipses the first elongated segment.
 4. The device of claim 1, wherein the frit does not overlap the scan driver in its entirety.
 5. The device of claim 1, wherein the scan driver extends generally in the first direction parallel to the first elongated segment.
 6. The device of claim 5, wherein the first elongated segment overlaps a portion of the scan driver facing the array.
 7. The device of claim 6, wherein the portion is elongated generally in the first direction.
 8. The device of claim 6, wherein the portion has a width defined in a third direction perpendicular to the first and second directions, and wherein the width is from about 0.05 mm to about 0.5 mm.
 9. The device of claim 1, wherein the scan driver has a width defined in a third direction perpendicular to the first and second directions, wherein the width is from about 0.2 mm to about 1.5 mm.
 10. The device of claim 1, wherein the scan driver comprises a wiring area, and wherein the first elongated segment overlaps with the wiring area when viewed in the second direction.
 11. The device of claim 1, wherein the scan driver comprises an active area, and wherein the first elongated segment overlaps with the active area when viewed in the second direction.
 12. The device of claim 1, further comprising an electrically conductive layer formed between the first elongated segment and the scan driver.
 13. The device of claim 12, wherein the array comprises an anode, and wherein the electrically conductive layer is deposited simultaneously with the anode.
 14. The device of claim 12, wherein the electrically conductive layer is reflective with respect to a laser beam or infrared beam.
 15. The device of claim 1, further comprising a planarization layer formed between the first substrate and the frit, and wherein the scan driver is substantially buried in the planarization layer.
 16. The device of claim 1, wherein the scan driver comprises an integrated circuit comprising a thin film transistor.
 17. The device of claim 1, wherein the frit seal comprises one or more materials selected from the group consisting of magnesium oxide (MgO), calcium oxide (CaO), barium oxide (BaO), lithium oxide (Li₂O), sodium oxide (Na₂O), potassium oxide (K₂O), boron oxide (B₂O₃), vanadium oxide (V₂O₅), zinc oxide (ZnO), tellurium oxide (TeO₂), aluminum oxide (Al₂O₃), silicon dioxide (SiO₂), lead oxide (PbO), tin oxide (SnO), phosphorous oxide (P₂O₅), ruthenium oxide (Ru₂O), rubidium oxide (Rb₂O), rhodium oxide (Rh₂O), ferrite oxide (Fe₂O₃), copper oxide (CuO), titanium oxide (TiO₂), tungsten oxide (WO₃), bismuth oxide (Bi₂O₃), antimony oxide (Sb₂O₃), lead-borate glass, tin-phosphate glass, vanadate glass, and borosilicate.
 18. A method of making an organic light emitting device, the method comprising:
 - providing a first substrate defining a pixel region and a non-pixel region;
 - forming an array of organic light emitting pixels over the pixel region of the first substrate;
 - forming a scan driver over the non-pixel region of the first substrate;
 - arranging a second substrate over the first substrate such that the array being interposed between the first and second substrates;
 - interposing a frit comprising a plurality of elongated segments between the first substrate and second substrate, the plurality of elongated segments in combination surrounding the array, and the plurality of elongated segments comprising a first elongated segment elongated generally in a first direction; and
 - wherein the scan driver overlaps with the first elongated segment when viewed in a second direction from the first or second substrate, wherein the shortest distance between the first and second substrates is defined in the second direction.
 19. The method of claim 18, wherein the first elongated segment substantially eclipses the scan driver.
 20. The method of claim 18, wherein an electrically conductive layer is interposed between the first elongated segment and the scan driver.

* * * * *

专利名称(译)	有机发光显示装置及其制造方法		
公开(公告)号	US20070176563A1	公开(公告)日	2007-08-02
申请号	US11/540083	申请日	2006-09-29
[标]申请(专利权)人(译)	KIM JONG DEUK 宋承宪YONG		
申请(专利权)人(译)	KIM JONG DEUK 宋承宪YONG		
当前申请(专利权)人(译)	KIM JONG DEUK 宋承宪YONG		
[标]发明人	KIM DEUK JONG SONG SEUNG YONG		
发明人	KIM, DEUK JONG SONG, SEUNG YONG		
IPC分类号	G09G3/10		
CPC分类号	H01L51/5246 H01L27/3276 A47C7/54		
优先权	1020060008768 2006-01-27 KR		
其他公开文献	US8796918		
外部链接	Espacenet USPTO		

摘要(译)

公开了一种有机发光显示装置，包括分成像素区域和非像素区域的第一基板。有机发光元件包括第一电极，有机薄膜层和形成在像素区域中的第二电极。在非像素区域中形成扫描驱动器和与扫描驱动器的区域对应的金属膜。第二衬底与第一衬底的像素区域和非像素区域间隔开。沿着第二基板的非像素区域的边缘形成玻璃料，其中形成玻璃料使得其可以与形成在非像素区域中的扫描驱动器的有源区域重叠。

